



Photo By: Antonio Busiello

Protocol Handbook For
**Monitoring Marine Water Quality
in the Mesoamerican Reef System**



Bay Islands Conservation Association, Coastal Zone Management
Authority and Institute, Healthy Reefs Initiative and The Coral Reef Alliance



This work was funded by the Summit Foundation and an anonymous donor.

Prepared By:

Mayra Núñez-Vallecillo, Zara Lizzeth Zúniga, Giselle Brady,
Samir Rosado and Antonella Rivera



Collaborators.

Melanie McField
Helen Fox
Jenny Myton
Javier Pizaña
Mélina Soto
Nicole Craig
Tanya Amaya
Alejandro López
Viridiana Nava
Juan Pedro Zapotecas
Rosa Loreto
Mireya Carrillo
Arlene Young
Arreini Palacio
Kirah Forman
Ely Augustinus
Braulio Gutiérrez
Ricardo González-Gil

Healthy Reefs Initiative
Coral Reef Alliance
Coral Reef Alliance
Coral Reef Alliance
Healthy Reefs Initiative
Healthy Reefs Initiative
Coral Reef Alliance
Centinelas del Agua
Centinelas del Agua
Centinelas del Agua
Amigos de Sian Ka'an
Amigos de Sian Ka'an
Coastal Zone Management Authority and Institute
Southern Environmental Association
Hol Chan Marine Reserve
Bay Islands Conservation Association, Utila chapter
Bay Islands Conservation Association, Utila chapter
Consultant



Contents.

| | |
|----|-----------------------------------------------|
| 6 | Introduction |
| 8 | Objectives |
| 10 | Parameters Descriptions |
| 12 | Sampling Design |
| 14 | Field Safety |
| 14 | Site Characterization |
| 14 | Quality Assurance and Quality Control (Qa/Qc) |
| 16 | Labelling Samples |
| 17 | Water Sampling |
| 18 | Pathogen Collection Protocol |
| 19 | Biophysical Parameters Collection Protocol |
| 20 | YSI ProDSS Calibration |
| 21 | Nutrient Collection Protocol |
| 21 | Ammonia (NH ₃) |
| 24 | Nitrite (NO ₂) |
| 25 | Nitrate (NO ₃) |
| 27 | Total Phosphorus (P) |
| 30 | Isotope Collection Protocol |
| 31 | Recording Information and Database Format |
| 32 | Bibliography |
| 33 | Annexes |

Acronyms and Abbreviations.

| | |
|--------------------------------------------------------|--------------------------------------------------|
| BICA: Bay Islands Conservation Association | MAR: Mesoamerican Reef System |
| CCME: Canadian Council of Ministers of Environment | MDL: Minimum Detection Level |
| CHL: Chlorophyll | MPA: Marine Protected Area |
| CON: Conductivity | MRL: Minimum Reportable Level |
| CZMAI: Coastal Zone Management Authority and Institute | PE: Total Algae Phycoerythrin |
| DO: Dissolved Oxygen | SAL: Salinity |
| GCC: Global Climate Change | SDWA: US Safe Drinking Water Act |
| LFB: Laboratory Fortified Blank | SOP: Standard Operating Procedures |
| LFM: Laboratory Fortified Matrix | WQ: Water Quality |
| | YSI: Water Quality Sampling and Monitoring Probe |

List of Figures.

| | |
|----------------------------------------------------------------------------------------------|----|
| Figure 1. Proposed water quality monitoring sites in the Mesoamerican Reef System (MAR)..... | 12 |
| Figure 2. Technique for taking samples in surface waters. Source: EPA, 2009..... | 17 |
| Figure 3. Standard volume of calibration vessel. Source: YSI ProDSS manual, 2018..... | 19 |
| Figure 4. Sensor calibration menu. Source: YSI ProDSS manual, 2018..... | 20 |

List of Tables.

| | |
|----------------------------------------------------------------------------------------------|----|
| Table 1. Water quality parameters and justification for measurement..... | 11 |
| Table 2. Water quality sampling sites in the MAR..... | 13 |
| Table 3. Characterization of the sites that will be monitored in phase 1 of the project..... | 15 |
| Table 4. Nomenclature for each monitoring location..... | 16 |
| Table 5. Materials and equipment to be used in marine water monitoring in MAR..... | 18 |
| Table 6. Materials for the collection of nutrients in marine water in the MAR..... | 20 |
| Table 7. Materials to be used in the collection of isotopes in marine water in the MAR..... | 30 |

Introduction.

Marine water quality monitoring is an important tool for the management of marine resources, as it allows the assessment of temporal and spatial trends in the quality or state of the environment (Baird et al., 2017). Monitoring the quality of marine water allows for the implementation of mitigation actions to prevent and deter environmental degradation. In the Mesoamerican Reef System (MAR) region, an increase in macroalgae has been reported in recent years (McField et al., 2020). Macroalgae blooms threaten the resilience of coral reefs as they grow on corals, prevent larval settlement, and compete for space (Mumby et al., 2014). Algal overgrowth is related to low herbivore populations and nutrient contamination due to inefficient wastewater management and unsustainable agricultural activities (McField et al., 2020).

Due to this problem, the need arose for better data on levels and sources of nutrient pollution in the MAR ecosystem, which is currently threatened and possesses many species that

are in critical danger of extinction (e.g. Nassau Grouper and species of the Acropora genus; Aronson et al., 2008). Although there are water quality data (WQ) monitoring programs in the MAR, their distribution is irregular in space and time.

Currently, travel restrictions and local lockdowns implemented within MAR countries as a result of the COVID-19 outbreak provide an unprecedented "natural experiment" to better understand a major source of nutrient pollution: tourism.

Due to this opportunity, a coordinated WQ monitoring program throughout the MAR was launched. This will allow any change in water quality to be quantified, particularly those parameters associated with wastewater impacts, along with changes in tourism levels as countries reopen their economic activities.

This project is divided into two phases to evaluate WQ in the MAR. Phase 1 consists of

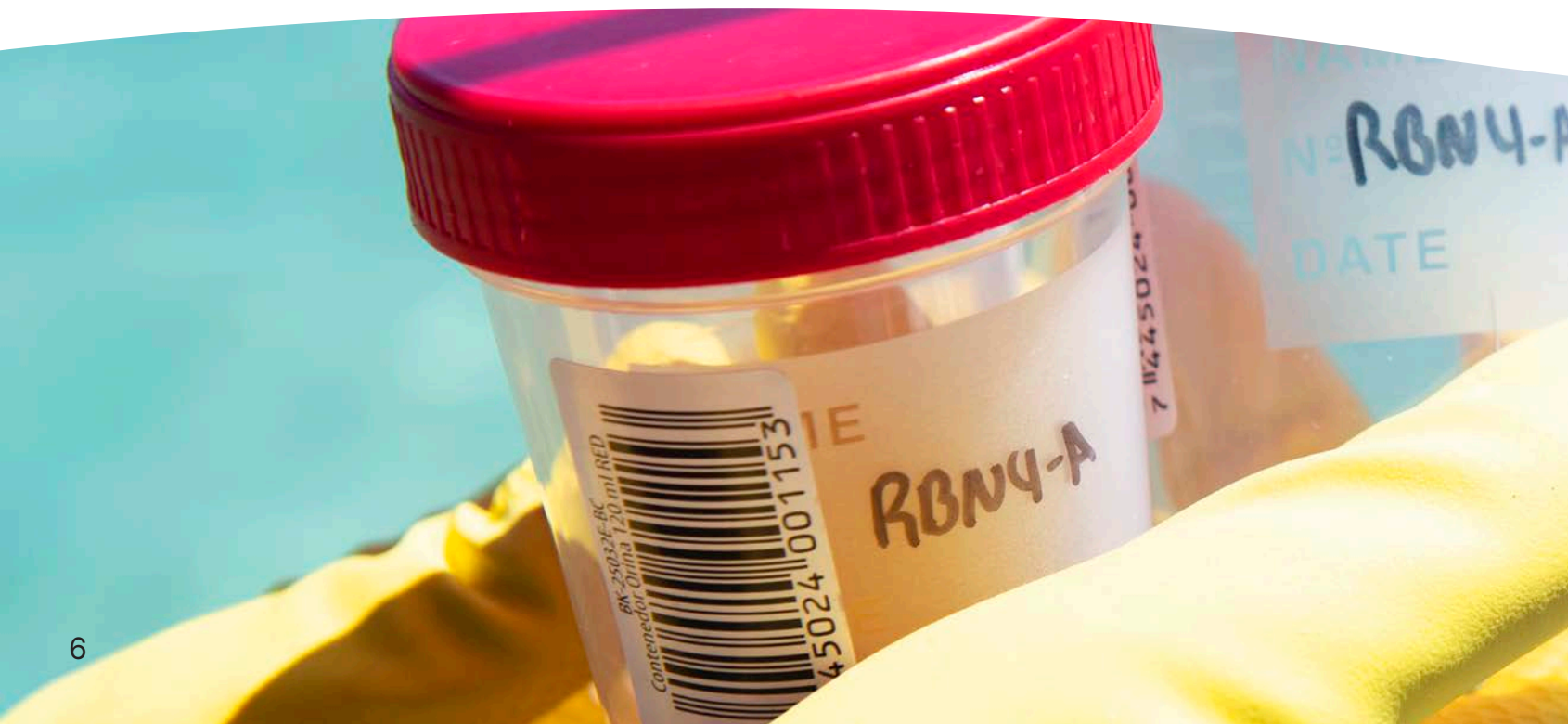

generating critical information focused on quantifying the human impacts derived from wastewater. Priority will be given to the sites where a greater impact of tourism is expected and will include key control sites that are not influenced by tourism-related fluctuations, providing much-needed quantitative data. The data collected during Phase 1, as well as from several complementary projects in a similar timeframe, would set the stage for a second phase. Phase 2 will spatially expand Phase 1 sampling sites to jointly assess nutrient enrichment arising from urban, agricultural, industrial, and tourist sources. All of this data will support growing efforts to implement specific solutions to improve regional water quality.

The project tries to answer the question of what is the relative and absolute contribution of wastewater generated by tourism activity, compared to other sources of nutrients in the key destinations of the MAR. For this, data with high spatial and temporal resolution will be

considered. Consequently, 5 sampling locations have been identified in each of the three MAR countries most affected by tourism (Honduras, Belize, and Mexico), and these are divided into three locations impacted by tourism and two control locations. At each of these sites, the main water quality parameters designed to elucidate and quantify these impacts will be sampled monthly.

This is the first coordinated water quality sampling project to be implemented in the MAR region, which will lay the foundations for prioritizing and targeting additional sampling needs, as well as more specific solutions.



Project Objectives.

Gather high spatial, and temporal, resolution data at sites where tourism-related sewage is expected to be a dominant pollution source, as well as comparison low-tourism (control) locations.

Quantify any changes in water quality, particularly those parameters associated with sewage impacts, alongside the changes in tourism levels as countries reopen their economies.

Coordinate regional research efforts aimed at understanding and improving water quality, including initial outreach to regulators and stakeholders.



Protocol Handbook Objectives.

Standardize monitoring protocols for the region, considering the methods for data collection of biophysical, pathogens, nutrients and isotopes parameters, to ensure comparisons among data.

Develop a unified database with the collected results on marine water quality in the MAR region.



Parameters Descriptions.

For this study, we are considering analyzing four types of indicators: biophysical, pathogens, nutrients, and isotopes. Each indicator has specific parameters that will help detect the effect of wastewater on marine waters of the MAR (Table 1). We will collect standard biophysical parameters in situ with a multi-parametric probe (YSI brand), including temperature, pH, salinity, oxygen, and chlorophyll (as a result of nutrient contamination in oligotrophic waters). To specifically target human wastewater, we will measure fecal indicator bacteria (enterococci and total coliforms) at all sites and perform an N isotope analysis (from macroalgae and seagrass), to estimate the percentage of nitrogen incorporated into the plant that is derived from human sewage. In addition, samples will be collected for immediate laboratory analysis of nutrients (nitrogen in various forms and total phosphorus) at beach sites where proximity to nutrient sources allows potential measurement even in oligotrophic tropical ecosystems. Samples will be analyzed in an established and certified laboratory in Mexico and in the main local laboratories in Honduras and Belize, thus ensuring the project helps build local capacity and national acceptance of the results. The units for each parameter are described in Annex I.

Table 1. Water Quality Parameters and Justification for Measurement

| Indicator | Parameter | Measurement | Justification |
|-------------|------------------------|-------------|----------------------------------------------------------------------------------------------------------------------------------------------------------------------------------------------------------------------------------------------------------------------------------------|
| Biophysical | Surface Temperature | On-Site | Required in some calculations; Global Climate Change Indicator (GCC). |
| | pH | On-Site | Required in some calculations; GCC. |
| | Total Suspended Solids | On-Site | Nutrient and sediment runoff indicator. It can reduce photosynthesis and the growth of coral reefs. |
| | Dissolved Oxygen | On-Site | Generally reduced as nutrient pollution increases. Low levels cause direct mortality of marine life. |
| | Conducivity | On-Site | Required for some calculations and instrumentation. |
| | Salinity | On-Site | Changes can indicate a freshwater runoff or advection of different water masses. |
| | Turbidity | On-Site | Indicator of nutrient runoff and sedimentation and possible phytoplankton blooms. |
| | Chlorophyll | On-Site | Proxy for phytoplankton biomass and, potentially, indicator of nutrient contamination in an oligotrophic environment, because phytoplankton immediately absorb nutrients from water. |
| Pathogen | Enterococcus | Laboratory | Specific indicator of human wastewater in marine waters. |
| | Total Coliforms | Laboratory | Generalized indicator of human wastewater, included in most regulations. |
| Nutrients | Nitrate | Laboratory | Final by-product of wastewater after biological treatment (natural or within a treatment plant) that provides N in the most available form for the growth of algae, bacteria and diseases, and ecological changes towards the proliferation of macroalgae with the decrease of corals. |
| | Nitrite | Laboratory | Intermediate product after some denitrification. |
| | Ammonia | Laboratory | Original by-product in human wastewater. |
| | Total Phosphorus | Laboratory | It can be the most limiting nutrient for the growth of macroalgae, also included in the wastewater effluent. |
| Isotope | N15 | Laboratory | It allows estimating the proportion of nitrogen in macroalgae derived from human wastewater. |

Figure 1. Proposed Water Quality Monitoring Sites in the Mesoamerican Reef System (MAR).

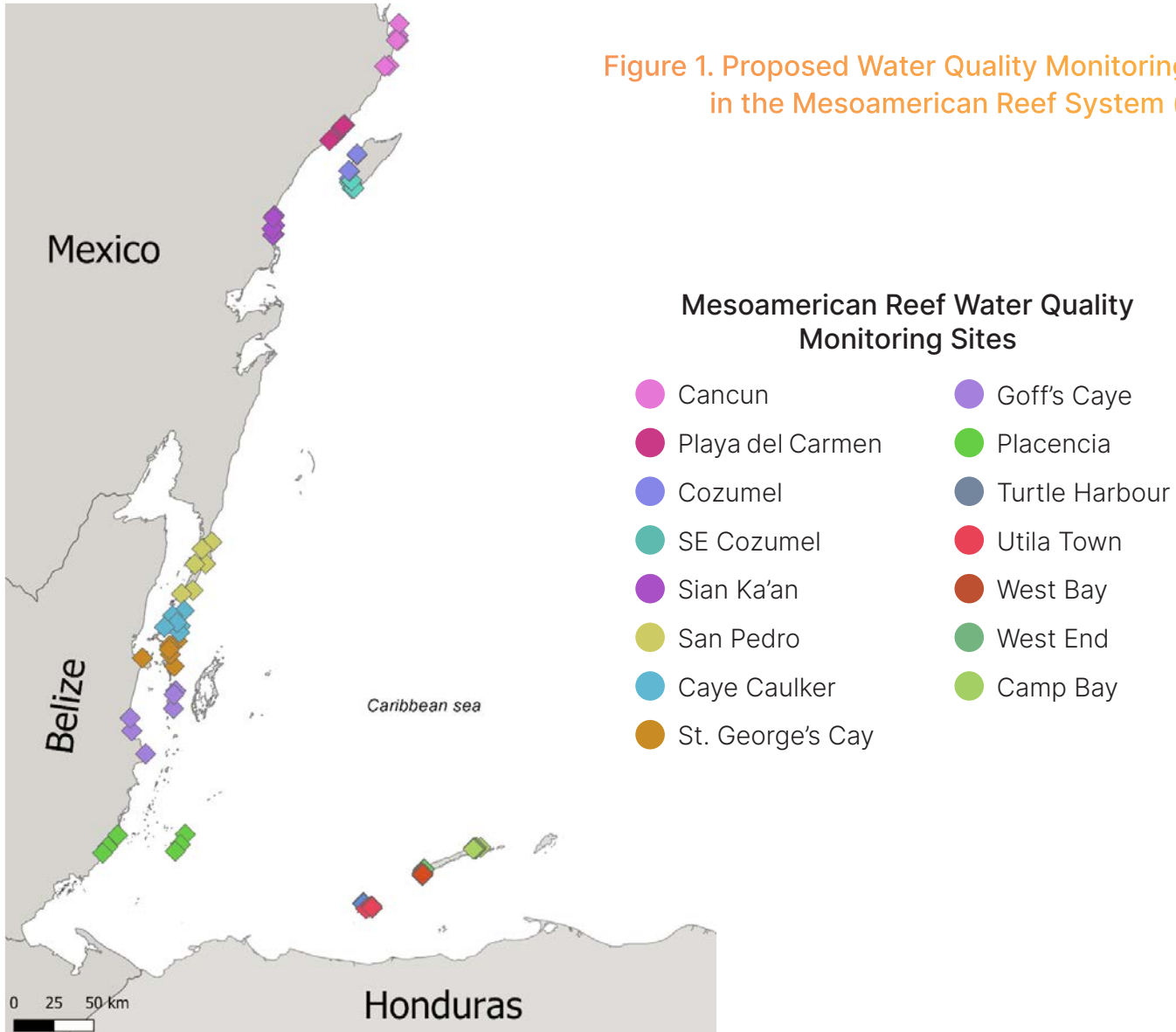

Sampling Design.

Site selection and sampling in this phase will focus on nine major tourist locations and six control locations least affected by tourism, including beaches and reefs that are expected to be the most affected by tourism-related wastewater pollution. Samples will be taken from coastal beaches and reef ecosystems that are expected to have a high impact from tourism-related wastewater and from places where such impacts are expected to be minimal based on existing knowledge of tourism infrastructure and physical oceanography (see Figure 1 and Table 2).

Our Before-After-Control-Impact approach provides a rigorous scientific basis for evaluating the impacts of tourism on WQ in the MAR. BICA's seven-year monthly sampling in the Bay Islands of Honduras has revealed substantial inter-site and intra-site variability; using this same monthly sampling frequency in this spatially expanded study will allow us to better understand the drivers of water quality in the MAR.

Table 2. Water Quality Sampling Sites in the MAR.

| Country | Treatment | Location | Ecosystem | No. of Sites | |
|----------------------|------------------|-------------------|------------------|--------------|----|
| Mexico | Control | Sian Ka'an | Beach | 3 | |
| | | | Reef | 3 | |
| | | Southwest Cozumel | Beach | 3 | |
| | | | Reef | 3 | |
| | Impacted | Cozumel | Beach | 3 | |
| | | | Reef | 3 | |
| | | Cancun | Beach | 3 | |
| | | | Reef | 3 | |
| | | Playa del Carmen | Beach | 3 | |
| | | | Reef | 3 | |
| | Belize | Control | St. George's Cay | Beach | 3 |
| | | | | Reef | 3 |
| Goff's Cay | | | Beach | 3 | |
| | | | Reef | 3 | |
| Impacted | | San Pedro | Beach | 3 | |
| | | | Reef | 3 | |
| | | Caye Caulker | Beach | 3 | |
| | | | Reef | 3 | |
| | | Placencia | Beach | 3 | |
| | | | Reef | 3 | |
| Honduras | | Control | Camp Bay | Beach | 3 |
| | | | | Reef | 3 |
| | Turtle Harbour | | Beach | 3 | |
| | | | Reef | 3 | |
| | Impacted | West End | Beach | 3 | |
| | | | Reef | 3 | |
| | | West Bay | Beach | 3 | |
| | | | Reef | 3 | |
| | | Utila Town | Beach | 3 | |
| | | | Reef | 3 | |
| | Total Sites | | | | 90 |
| | Total Reef Sites | | | | 45 |
| Total Beach Sites | | | | 45 | |
| Total Sites Impacted | | | | 54 | |
| Total Control Sites | | | | 36 | |

Field Safety.

On the sampling day, a field safety plan will be sent to the organization coordinating the monitoring, which includes: data on the monitoring participants (names and surnames, identification number, insurance number and telephone number), description of the vessel (name, registration number, port, names of the owner and captain and their contacts), time, date, place where the monitoring will be carried out and an emergency contact to contact in the event that the vessel does not arrive at the time indicated in the field safety plan (Annex II). Additionally, each boat should have a first aid kit, life jackets, radio, hypothermic blankets and water/juices. Furthermore, notice will be given to MPA officials no less than 24 hours before departure.

Site Characterization.

The sites selected for this study were based on the presence of reefs and beaches, as well as the number of tourists they receive. However, each site has different conditions according to its geographic location, such as the type of marine habitat and the flow speed of marine currents. These aspects are key considering the transport and diffusion of pollutants to other areas through marine currents (Table 3). This characterization will be validated in the field using CZMAI's site characterization sheet (Annex III).

Quality Assurance and Quality Control (QA/QC).

An important step in monitoring is to check the integrity of the water samples, thus according to the *Canadian Council of Ministers of the Environment* (CCME) it is necessary to take quality control samples or "blanks". Blank samples can be used to determine if contamination could enter a water sample during transport (shooting blank) or throughout the sampling process (blank field). Blank samples are useful for:

1. Testing the purity of chemical preservatives.
2. Check for possible contamination of sample containers, filter papers, filtration equipment or any other equipment used in the collection, handling or transport of samples.
3. Detect contamination that occurs during sampling.
4. Detect other systemic and random errors that occur from the time of sampling to the time of analysis.

Blank samples are generally prepared in the laboratory and simply travel with the sample bottles from the laboratory to the sample site and then back to the laboratory unopened until the time of analysis (CCME, 2011). Blank sample preparation is detailed in each parameter section.

Table 3. Characterization of the Sites that will be Monitored in Phase 1 of the Project.

| Country | Location | Marine Habitat | Average Speed of Sea Currents (m/s) | Source |
|----------|-------------------|----------------------------------------------------------------------------------|-------------------------------------|--------------------------------------------------------|
| Mexico | Sian Ka'an | Coral structure, octocorals, and debris, seagrass, rocky reef and coastal lagoon | 0.31 | Cerdeira-Estrada et al., 2018; Tyberghein et al., 2012 |
| | Southwest Cozumel | Coral structure | 0.85 | |
| | Cancun | Coral structure, seagrasses and macroalgae, stumps and coral pieces | 0.55 | |
| | Playa del Carmen | Stumps and pieces of coral, macroalgae, octocorals and corals | 0.74 | |
| Belize | St Georges Cay | Reef patches, shallow reef and seagrass | 0.10 | Tyberghein et al., 2012; Maidens and Burke, 2005 |
| | Goff's Cay | Reef patches, shallow reef, seagrasses, channels and ridges | 0.11 | |
| | San Pedro | Reef patches, shallow reef, seagrasses, channels and ridges | 0.12 | |
| | Caye Caulker | Reef patches, shallow reef, seagrasses, channels and ridges | 0.09 | |
| | Placencia | Reef patches, shallow reef, seagrasses, channels and ridges | 0.15 | |
| Honduras | Camp Bay | Pavement with gorgonian and turf algae, aggregated reef patch and seagrass | 0.24 | Purkis L., 2016; Tyberghein et al., 2012 |
| | Turtle Harbour | Aggregate reef, reef patch and lagoon and seagrasses | 0.17 | |
| | West End | Pavement with gorgonian and turf algae | 0.22 | |
| | West Bay | Aggregate reef patch, pavement with gorgonian and turf algae | 0.22 | |
| | Utila Town | Aggregate reef and reef patch and seagrasses | 0.15 | |

Table 4. Nomenclature for Each Monitoring Location.

| Location | Site | Abreviation |
|---------------------------|-------|-------------|
| Sian Ka'an | Beach | SKP |
| | Reef | SKA |
| Southwest Cozumel | Beach | SCP |
| | Reef | SCA |
| Cozumel | Beach | CZP |
| | Reef | CZA |
| Cancún | Beach | CAP |
| | Reef | CAA |
| Playa del Carmen | Beach | PCP |
| | Reef | PCA |
| St. Georges Caye | Beach | SGP |
| | Reef | SGA |
| Goff's Caye | Beach | GCP |
| | Reef | GCA |
| San Pedro | Beach | SPP |
| | Reef | SPA |
| Caye Caulker | Beach | CCP |
| | Reef | CCA |
| Placencia | Beach | PLP |
| | Reef | PLA |
| Camp Bay | Beach | CBP |
| | Reef | CBA |
| Rock Harbor-Turtle Harbor | Beach | RHP |
| | Reef | RHA |
| West End | Beach | WEP |
| | Reef | WEA |
| West Bay | Beach | WBP |
| | Reef | WBA |
| Utila Town | Beach | UTP |
| | Reef | UTA |
| Blank sample | Beach | BP |
| | Reef | BR |

Labeling Samples.

The samples must be identified according to categories (Table 4): site, type of analysis and the order of collection. As a first step for nomenclature, it is recommended to define and assign the characters used in each collection location. Table 3 provides a reference to the nomenclature by location. It is recommended to label sterile jars before sampling.

Sequentially, each site within the locality must be accompanied with the numbering "1", "2" and "3". In addition, it is recommended to place the type of analysis that will proceed after the collection of the sample:

- "C" for Coliforms
- "E" for Enterococci
- "N" for Nitrate
- "NI" for Nitrite
- "A" for Ammonia
- "F" for Phosphorus
- "I" for Isotopes

For enterococci samples, 3 replicates are collected per site. Thus, a sample number must be included in the nomenclature to indicate each replicate. Finally, assign a date.

Example:

[Letter (location), number (site), letter (analysis), number (samples)] + Date (dd/mm/yy)

For example, the samples taken for enterococci at the first reef site in Utila Town will be as follows:

**UTA1E01
01/07/21**

Water Sampling.

Sample collectors should keep their hands clean, wear gloves during sample collection and refrain from eating or smoking while working with water samples. Exhaust gases and cigarette smoke can contaminate samples with lead and other heavy metals (CCME, 2011).

According to the *Standard Methods for the Examination of Water and Wastewater*, the procedure for sample collection is as follows:

1. Keep the sterile 100 mL bottles (previously labeled) in the cooler at a temperature of $4^{\circ}\text{C} \pm 2^{\circ}\text{C}$ for transport.
2. Put on protective gloves.
3. Remove the cap from the container.
4. Rinse the bottle 3 times with water from the site to be sampled.
5. Grab the bottom of the container and immerse it (upside down) at approximately 20-30 cm.
6. Rotate the container toward the current or waves and away from the boat (See Figure 2).
7. Allow the water to enter the container for 30 seconds.
8. Cover the container while submerged and immediately remove it from the water (it is recommended to put parafilm on the bottle cap to secure the sample).
9. After removing the container from the water, a small portion of the sample should be discarded to allow adequate mixing before analysis (EPA, 2009).
10. Place the sample in the cooler over the ice (not on the melted water) at a temperature of $<10^{\circ}\text{C}$ and transport the samples to the laboratory.
11. It is recommended to take 3 samples from each site as a backup.

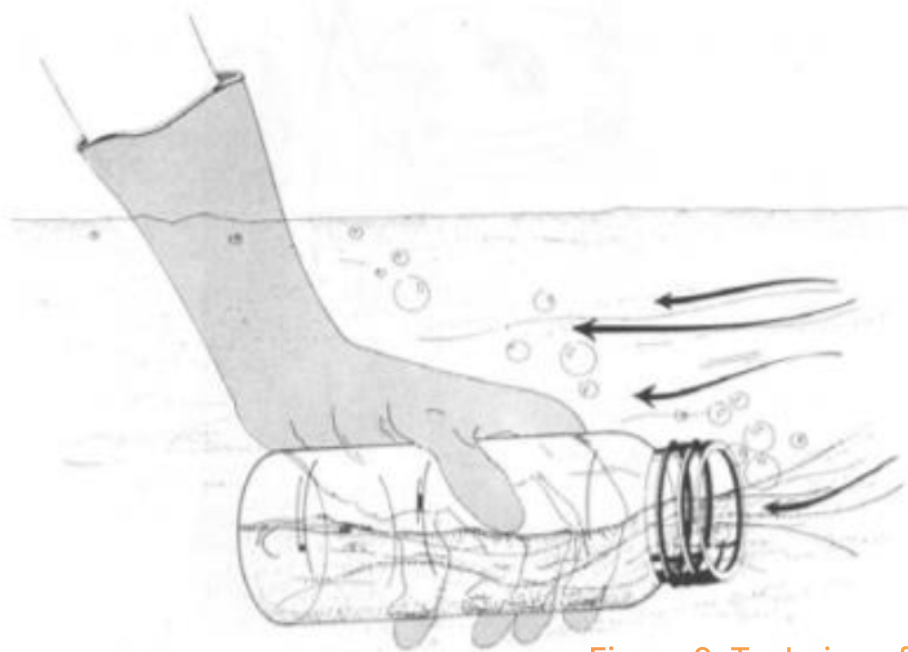

Figure 2. Technique for Taking Samples in Surface Waters. Source: EPA, 2009.

Table 5. Materials and Equipment to be Used in Marine Water Monitoring in MAR.

| Materials and Equipment | Amount per Site | Total MAR sites |
|----------------------------------|-----------------|-----------------------------|
| Sterile 100 mL Jars | 4 | 360 |
| Coolers | 2 | 180 |
| Cubed Ice Bags | 4 | 360 |
| Field Sheets on Waterproof Paper | 2 | 180 |
| Graphite Pencil Package | 1 | 90 |
| Permanent Marker | 2 | 180 |
| Secchi Disk | 1 | 10 (number of MAR partners) |
| GPS | 1 | 10 (number of MAR partners) |
| Waterproof Camera (optional) | 1 | 10 (number of MAR partners) |

Pathogen Collection Protocol.

Fecal coliforms and enterococci are the most appropriate indicators to determine the presence of fecal contamination in a body of water (Herrera and Suárez, 2005). The presence and degree of fecal contamination is an important factor in assessing water quality.

Examination of water samples can detect the presence of organisms of the coliform bacteria group, providing an indicator of contamination. Since the ability of some organisms of the coliform bacteria group to survive in water is limited, their numbers can also be used to estimate the degree of recent fecal contamination. On the other hand, the measurement of enterococci is a specific indicator of fecal contamination in water (Baird et al., 2017) responsible for gastroenteritis; their presence indicates recent contamination.

Several studies have indicated that enterococci are the best indicators for detecting the presence of microbiological contamination in recreational waters (Shibata et al., 2004).

Materials and Equipment.

The materials and equipment necessary for the collection of samples to analyze pathogens per sampling site are reflected in Table 5.



Biophysical Parameters Collection Protocol.

The biophysical parameters are taken by means of a YSI ProDSS multiparameter probe. This instrument is calibrated 1 to 3 days before the sampling day.

YSI ProDSS Calibration.

During the calibration of the pH, conductivity and turbidity parameters, the following indications should be considered (YSI, 2014):

- Make sure the calibration beaker, sensor guard, and all sensors are clean.
- If you are using the calibration cup, be sure to install the sensor shield before placing the sensors in the calibration cup.
- The sensor shield and calibration cup should be used for the calibration of turbidity and dissolved oxygen. Other calibrations can be performed on other glass instruments.
- Make sure to use a clean probe protector during calibration to avoid contamination of the calibration environment.

The following steps should be taken:

1. Install a clean, dry sensor and sensor protector on the head.*
2. Fill the calibration cup with a moderate amount of water and fit the calibration cup on the head. Use the water to rinse

the glass and the sensor to be calibrated. Discard the rinse water.

3. Thoroughly rinse the calibration beaker with a small amount of calibration standard to allow for the calibration of the sensor. Discard the calibration standard.
4. Refill the calibration beaker with new calibration standard to approximately the first line for pH and turbidity calibration. Fill to the second line for conductivity calibration (See Figure 3).**
5. Immerse the sensors in the standard and fit the calibration beaker on the device's head.***
6. Calibrate the sensors.****

Figure 3. Standard Volume of Calibration Vessel. Source: YSI ProDSS Manual, 2018.

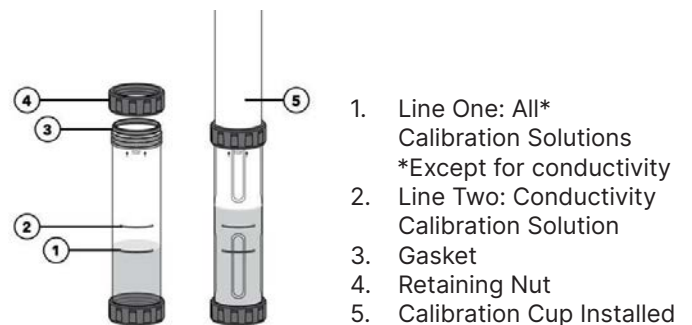

* Install a gray port plug on all exposed ports. All sensors must have a sensor or port plug installed.

** Volumes may vary. Make sure the temperature sensor and the sensor to be calibrated are submerged in the calibration solution, except when performing a % of dissolved oxygen saturation calibration.

*** Take care to avoid cross contamination with other standards.

**** These rinse recommendations are only suggested guidelines for maximum data accuracy. Be sure to follow your organization's Standard Operating Procedures (SOPs) for instrument calibration and operation.



Figure 4. YSI Probe Calibration Menu.
Source: YSI ProDSS manual, 2018.

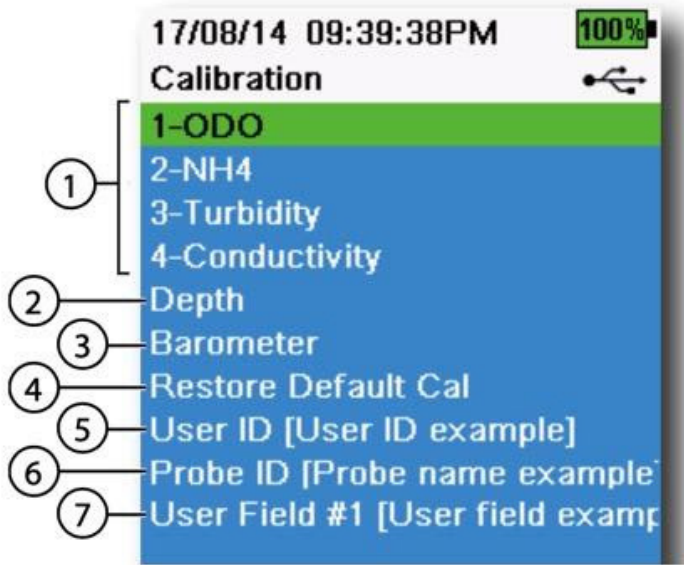

- | | |
|------------------------------------------------------|---------------|
| 1. Sensors Connected to the Head | 5. User ID |
| 2. Optional Depth Sensor Calibration | 6. Probe ID |
| 3. Barometer Calibration | 7. User Field |
| 4. Restore Default Calibration (Factory Settings) | |

Calibration Menu:

Follow the instructions below, which are based on the instruction manual for the YSI ProDSS:

1. Press the Cal key to access the Calibration menu (Figure 4). Highlight a submenu and press the ENTER key to view the submenu options.
2. Predefined or user-selected parameters are indicated in brackets ([]).
3. See the Calibration section for specific calibration procedures (see previous section).

NOTE: Connected sensors are listed according to the header port in which they are installed.

NOTE: User ID, Probe ID, and User Fields #1 and #2 must be enabled in the GLP menu to appear in the Calibration menu.

On-site Biophysical Data Collection.

Once you arrive at the sampling site, in the YSI ProDSS probe go to the option “Register a sample”, choose the code of the site to be sampled, immerse the sensors 50 cm in the site and press the option “Register now”. Wait for the values to stabilize and proceed to write the data for:

- Time, Temperature, DO (Dissolved Oxygen), SPCOND (Conductivity), SAL (Salinity), pH, CHL (Chlorophyll) and PE (Total Algae-Phycoerythrin).

Values should be recorded 3 times at each site (both on the YSI and on the data sheet). If it’s possible, for sites with a depth of ≥ 6 ft, biophysical data should also be collected at that depth by immersing the sensor as close to the substrate as possible.

Table 6. Materials for the Collection of Nutrients in the MAR’s Marine Water.

| Materials | Amount per Site | Total MAR Sites |
|-----------------------------|-----------------|-----------------|
| Sterile 250 mL Jars | 4 | 360 |
| Coolers | 2 | 180 |
| Cubed Ice Bags | 4 | 360 |
| Waterproof Field Sheets | 2 | 180 |
| Package of Graphite Pencils | 1 | 90 |
| Permanent Marker | 2 | 180 |

Nutrient Collection Protocol.

The collection of nutrient parameters will be carried out exclusively in beach sites, since reef sites tend to be oligotrophic, and nutrients are rapidly consumed, which makes it hard to obtain a signal. Monitoring parameters include ammonia (an omnipresent pollutant), nitrate, nitrite and total phosphorus (Baird et al., 2017; O'Dell, 1993).

Ammonia (NH₃).

- Take a 250 mL water sample in a container that has been labeled and sterilized; the collected volume must be sufficient to ensure representativeness of the sample.
- Minimize exposure of samples to air as much as possible (EPA, 2001). The most reliable results are obtained with fresh samples. Samples must be analyzed within 24 hours of collection.
- Refrigerate at 4°C, without acidifying. For preservation up to 28 days, freeze at -20 °C without acidifying or preserve samples by acidifying to a pH of 2 and storing at 4 °C.
- If acid preservation is used, neutralize samples with NaOH or KOH immediately before making the determination.

CAUTION: Although acidification is suitable for certain types of samples, it causes interference when exchangeable ammonia is present in unfiltered solids.

TYPE OF CONTAINER: Samples should be collected in wide-mouth plastic or glass jars with the minimum possible air space within the sample (EPA, 2001).

Protocol to Obtain Ammonia in the Laboratory.

1. Load and run the AC2012 method.
2. Fill a clean 24 mm round AQUAfast vial, cat. No. AC2V24, with a 10 mL sample. Close the vial tightly with the cap. Clean the outside of the vial.
3. Place the vial in the sample chamber holder and close the chamber door.
4. Touch the "Blank" soft key to measure the blank.
5. Open the sample chamber door and remove the vial from the holder.
6. Add the n. 1 ammonia tablet directly from the package to the vial. Crush the tablet with a clean stirring rod.
7. Add the n. 2 ammonia tablet directly from the package to the same sample in the vial. Crush the tablet with a clean stirring rod.
8. Close the vial tightly with the cap and twist or invert several times until the tablets are dissolved. Clean the outside of the vial.
9. Wait for a reaction during a 10-minute period.
10. Place the vial in the sample chamber holder and close the chamber door.
11. Touch the "Sample" soft key to display the result in mg/L ammonia as N.

NOTES:

- This method is an adaptation of Standard Methods 4500-NH₃ F, used by BICA.
- This method requires the commercial test kit AC2012.
- This method has a detection range of 0.02 - 1 mg/L N.
- The AC2012 commercial kit is compatible with the following instruments: Orion AquaMate Vis and UV-Vis Spectrophotometers, Orion AQUAfast AQ4000 Colorimeter, Orion AQUAfast.





Quality Control.

Method Blank: Follow the same procedure previously described in “Method to obtain ammonia” but use ultrapure water instead of a sample. Results must not be greater than half the minimum reportable limit ($> 1/2$ MRL). In this case, the results should not be greater than 0.01 mg/L N. Samples with a contaminated blank must be re-analyzed. Perform the Method Blank before analyzing the samples.

Laboratory Fortified Blank (LFB): Follow the same procedure previously described in “Method to obtain ammonia” but use ultrapure water to which a known analyte concentration has been added. The concentration must be at least 10 times the minimum detection level (MDL) or minimum reporting level (MRL). For this test, use a 0.2 mg/L N solution. To prepare this solution, dilute 0.7638 mg NH_4Cl in 1 L of ultrapure water. Process solution as a normal sample.

Laboratory Fortified Matrix (LFM): Follow the same procedure previously described in “Method to obtain ammonia”, use a sample (not distilled water) to which a known analyte concentration has been added. The added analyte concentration must be equal to the LFB, in this case 0.2 mg/L N. Prepare the solution in the same way: dilute 0.7638 mg NH_4Cl in 1 L of sample (not distilled water). If you do not have enough sample, adjust the volume to maintain a concentration of 0.2 mg/L N. Separately determine the concentration of the sample prior to adding the reagent and correct the results based on the background concentration.

Nitrite (NO₂).

- Take a 250 mL water sample (the collected volume must be sufficient to ensure representativeness of the sample), the sample container must be previously labeled and sterilized.
- Never use acid preservation for samples that will be tested for NO₂.
- Perform determination immediately on fresh samples to avoid bacterial conversion of NO₂ to NO₃ or NH₃.
- For short-term preservation of 1 to 2 days, freeze at -20° C or store at 4° C.

Protocol to Obtain Nitrite in the Laboratory.

1. Load and run method AC2046.
2. Fill a clean 24 mm round AQUAfast vial, cat. No. AC2V24, with 10 mL of sample. Close the vial tightly with the cap. Clean the outside of the vial.
3. Place the vial in the sample chamber holder and close the chamber door.
4. Touch the "Blank" soft key to measure the blank.
5. Open the sample chamber door and remove the vial from the holder.
6. Add one LR nitrite tablet directly from the package to the vial. Crush the tablet with a stirring rod.
7. Close the vial tightly with the cap and twist or invert several times until the tablet is dissolved. Clean the outside of the vial.
8. Wait for a reaction during a 10-minute period.
9. Place the vial in the sample chamber holder and close the chamber door.
10. Press the "Sample" soft key to display the result in mg/L nitrite as N.

NOTES:

- This method is an adaptation of the Standard Methods 4500-NO₂ B used by BICA.
- This method requires the commercial test kit AC2046.
- This method has a detection range of 0.01 - 0.5 mg/L N.
- The AC2046 commercial kit is compatible with the following instruments: Orion AquaMate Vis and UV-Vis Spectrophotometers, Orion AQUAfast AQ4000 Colorimeter, Orion AQUAfast.

Quality Control.

The samples should not be preserved in acid as this causes them to transform into nitrate. Three different quality control methods will be applied:

Method Blank: Follow the same procedure previously described in “Method to obtain nitrite” but use ultrapure water instead of sample. Results must not be greater than half the minimum reportable limit ($> 1/2$ MRL). In this case, the results should not be greater than 0.005 mg/L N. Samples with a contaminated blank must be re-analyzed. Perform the Method Blank before analyzing the samples.

Laboratory Fortified Blank (LFB): Follow the same procedure previously described in “Method to obtain nitrite” but use ultrapure water to which a known analyte concentration has been added. The concentration must be at least 10 times the minimum detection level (MDL) or minimum reportable limit (MRL). For this test, use a 0.1 mg/L N solution. To prepare this solution, dilute 0.4926 mg NaNO_2 in 1 L of ultrapure water. Process solution as a normal sample.

Laboratory Fortified Matrix (LFM): Follow the same procedure previously described in “Method to obtain nitrite” but use a sample (not distilled water) to which a known analyte concentration has been added. The added analyte concentration must be equal to the LFB, in this case 0.1 mg/L N. Prepare the solution in the same way: dilute 0.4926 mg NaNO_2 in 1 L of sample (not distilled water). If you do not have enough sample, adjust the volume to maintain a concentration of 0.2 mg/L N. Separately determine the concentration of the sample prior to adding the reagent and correct the results based on the background concentration.

Nitrate (NO_3).

- Take a 250 mL water sample in a labeled and sterilized container; the collected volume must be sufficient to ensure representativeness of the sample.
- Collect samples in polyethylene, fluoropolymer, or glass containers. If possible, start NO_3 analyzes immediately after sampling.
- Samples can be stored without acidification for up to 48 hours at 6 °C. Acidification transforms any nitrite (NO_2) to nitrate (NO_3). As a result, the NO_3 values of acidified samples are the sum of NO_3 and NO_2 .
- If samples have to be stored for prolonged period of time they should first be stored for 48 h, acidified to pH 2 with sulfuric or hydrochloric acid (depending on method) and lastly stored at 6° C or 2 to 6° C. Samples using this method are in accordance with SDWA (US Safe Drinking Water Act) and last up to 28 days. Chlorinated samples are stable for at least 14 days without acid preservation.

Protocol to Obtain Nitrate in the Laboratory.

1. Load and run method ACR007.
2. Open a 16 mm reaction vial (Reagent A) and add 1 mL of deionized water (this is the blank vial).
3. Open a second 16 mm reaction vial (Reagent A) and add 1 mL of sample (this is the sample vial).
4. Add the contents of one packet of chromotropic nitrate powder directly from the packaging to each bottle.
5. Close the vials tightly with the stoppers and gently invert about 10 times to mix the contents. Some solids may not dissolve. Clean the outside of the vials.
6. Wait for a reaction during a 5-minute period.
7. Place the blank vial in the sample chamber holder and close the chamber door.
8. Touch the "Blank" soft key to measure the blank.
9. Open the sample chamber door. Remove the blank vial from the holder.
10. Place the sample vial in the sample chamber holder and close the chamber door.
11. Touch the "Sample" soft key to display the result in mg/L nitrate as N.

NOTES:

- This method requires the commercial test kit ACR007.
- This method has a detection range of 1 - 30 mg/L N.
- The ACR007 commercial kit is compatible with the following instruments: Orion AquaMate Vis and UV-Vis Spectrophotometers, Orion AQUAfast AQ3700 Colorimeter.

Quality Control

Laboratory Fortified Blank (LFB): Follow the method described in the previous section in "Method to obtain nitrate" but use ultrapure water to which a known analyte concentration has been added. The concentration must be at least 10 times the minimum detection level (MDL) or minimum reportable limit (MRL). For this test, use a 10 mg/L N solution. To prepare this solution, dilute 72.182 mg of KNO_3 in 1 L of ultrapure water. Process solution as a normal sample.

Laboratory Fortified Matrix (LFM): Follow the method described in the previous section in "Method to obtain nitrate" but use a sample (not distilled water) to which a known analyte concentration has been added. The added analyte concentration must be equal to the LFB, in this case 10 mg/L N. Prepare the solution in the same way: dilute 72.182 mg KNO_3 in 1 L of sample (not distilled water). If you do not have enough sample, adjust the volume to maintain a concentration of 10 mg/L N. Separately determine the concentration of the sample prior to adding the reagent and correct the results based on the background concentration.

Total Phosphorus (P).

- Take a 250 mL water sample (the collected volume must be sufficient to ensure representativeness of the sample), the sample container must be previously labeled, sterilized, and rinsed with a 10% hydrochloric acid solution to prevent phosphorus from adhering to the container walls.
- If forms of dissolved phosphorus are to be distinguished, filter the sample immediately after collection.
- Sample should be immediately frozen at or below 10 °C. In case of not having adequate refrigeration preserve with HgCl_2 , 40 mg HgCl_2 / L can be added to samples (Wong et al., 2017).
- If total phosphorus is to be determined, add H_2SO_4 or HCl at a pH of 2 and cool at 4° C, or freeze without additions.
- Do not store samples containing low concentrations of phosphorus in plastic bottles unless they are kept frozen because phosphates can be absorbed by the walls of the plastic bottles.
- Rinse all glass containers with hot diluted HCl , then rinse several times with reagent water. Never use commercial detergents that contain phosphate to clean glassware used for the analysis of total phosphorus. Stronger cleaning techniques can be used.

CAUTION: HgCl_2 is a dangerous substance; take the necessary precautions for its elimination. If it is not strictly necessary, the use of HgCl_2 is not recommended. Do not add acid or CHCl_3 as a preservative when determining the forms of phosphorus.



Protocol to Obtain Phosphorus in the Laboratory.

1. Open a 16 mm PO₄-P Acid Reagent Digestion Tube and add 5 mL of sample.
2. Add the contents of one packet of Potassium Persulfate F10 powder directly from the packet to the bottle. Use a funnel to add the reagent.
3. Close the vial tightly with the cap and invert the vial several times to mix the contents.
4. Heat the vial for 30 minutes in the preheated reactor at a temperature of 100 ° C. **CAUTION:** The vial will be hot. Remove the vial from the reactor and allow it to cool to room temperature.
5. Open the cooled digestion vial and add 2 mL of 1.54 normal sodium hydroxide solution to the bottle.
6. Close the vial tightly with the cap and gently invert the vial several times to mix the contents. Clean the outside of the vial.
7. Load and run method ACD095 on the spectrophotometer.
8. Place the vial in the sample chamber holder and close the chamber door.
9. Touch the "Blank" key to measure the blank.
10. Open the sample chamber door. Remove the vial from the holder.
11. Add the contents of one packet of Potassium Persulfate F10 powder directly from the packet to the vial. Use a funnel to add the reagent.
12. Close the vial tightly with the cap and shake the vial for 10-15 seconds to mix the contents. The reagent will not dissolve completely. Clean the outside of the vial.
13. Wait for a reaction during a 2-minute period.
14. Place the vial in the sample chamber holder and close the chamber door.
15. Touch the "Sample" key to display the result in mg/L of total phosphorus.

NOTES:

- This method is adapted from Standard Methods 4500-P E.
- This method requires the ACD095 commercial test kit.
- This method has a detection range of 0.02 - 1.1 mg/L P.
- The ACD095 commercial kit is compatible with the following instruments: Orion AquaMate Vis and UV-Vis Spectrophotometers, Orion AQUAfast AQ3700 Colorimeter.

Quality Control.

The samples must be collected in jars previously rinsed with a 10% HCl solution to prevent phosphorus from adhering to the walls of the flask. 3 different quality control methods will be applied:

Method Blank: Follow the same procedure previously described in “Method to obtain phosphorus” but use ultrapure water instead of a sample. Results must not be greater than half the minimum reportable limit ($> 1 / 2$ MRL). In this case, the results should not be greater than 0.01 mg/L P. Samples with a contaminated blank must be re-analyzed. Perform the Method Blank before analyzing the samples.

Laboratory Fortified Blank (LFB): Follow the same procedure previously described in “Method to obtain phosphorus” but use ultrapure water to which a known analyte concentration has been added. The concentration must be at least 10 times the minimum detection level (MDL) or minimum reportable limit (MRL). For this test, use a 0.2 mg/L P solution. To prepare this solution, dilute 0.8787 mg of KH_2PO_4 in 1 L of ultrapure water. Process solution as a normal sample.

Laboratory Fortified Matrix (LFM): Follow the same procedure previously described in “Method to obtain phosphorus” but use a sample (not distilled water) to which a known analyte concentration has been added. The added analyte concentration must be equal to the LFB, in this case 0.2 mg/L. Prepare the solution in the same way: dilute 0.8787 mg of KH_2PO_4 in 1 L of sample (not distilled water). If you do not have enough sample, adjust the volume to maintain a concentration of 0.2 mg/L. Separately determine the concentration of the sample prior to adding the reagent and correct the results based on the background concentration.



Isotope Collection Protocol.

The following protocol has been adapted from Dustan, 2021. Since there is no clear knowledge of when tourism will restart, a design scheme has been created that allows for fine-scale oversampling and then choosing samples to reflect the temporal nature of the restart (P. Dustan personal communication).

Table 7. Materials for the Collection of Isotopes in the MAR's Marine Water.

| Materials | Amount per Site | Total Amount |
|-----------------------------|-----------------|--------------|
| Small Sterile Containers | 4 | 360 |
| Roll of Aluminum Foil | 2 | 180 |
| Box of Latex Gloves | 1 | 90 |
| Waterproof Field Sheets | 2 | 180 |
| Package of Graphite Pencils | 1 | 90 |
| Permanent Marker | 2 | 180 |

Collection.

- The samples will be collected using gloved hands, so as not to contaminate or transfer nitrogen to the samples in any way.
- Sampling seasonality will be determined once the sites have been characterized. Take care to select individual plants that reflect fresh growth during the sample period. Seagrass samples (*Thalassia* spp.) will be taken at coastal sites and green macroalgae (*Halimeda* spp.) at reef sites.
- In general, plants should be far enough apart to ensure each thallus ("leaf") is from a different plant. Ten (10) thalli (1-2 cm in width) will be collected at each site. Each site will have 3 replicates, each replicate will be comprised of 3 thalli.
- Any excess debris will be cleaned off each sample before storing it in a small container to avoid physical damage. Once out of the water, the samples will be rinsed with double distilled water to rinse off any debris, small encrusting organisms, or other impurities. If clean distilled water is not available, use the cleanest seawater you can obtain. All the samples should be washed in the same water to ensure they are all exposed to the same conditions. Again, samples will be handled with gloved hands to prevent contamination.
- After rinsing, the leaves should be dabbed dry with a paper towel and then placed in folded aluminum foil square. The thallus is stored flat on aluminum foil. Each sample will be photographed including a scale and the sample label to take morphometric measurements in the future.
- Samples should be dried to the point of being "crispy" in a food dehydrator for a period of 6-12 hours. A rice cooker, or oven on warm may suffice if temperatures do not exceed ~50-60 °C. Samples should be stored in a dry environment prior to shipping to the lab for analysis.

Aluminum Foil Handling to Prevent Contamination.

- Wear nitrile or latex gloves to prevent contamination.
- Unroll an aluminum sheet approximately 50 cm with the inside surface (cleanest side) facing up as a working surface.
- Unroll shorter lengths to be cut into squares (~15×15 cm) and place on the working surface foil with the inside facing up
- Fold the working surface foil into a small envelop to store cut squares.
- Place a single thallus on a square, fold lightly to allow for dehydration to occur.
- Dehydrate sample, then tighten fold for storage.
- Group collections into small aluminum “envelopes” and add a label on the inside using the sample nomenclature.
- Write label using permanent ink on both the paper label as well as on the outside of each aluminum foil packet.
- Store sample packs in humidity-controlled container- large jar with desiccant, in an air-conditioned room to keep dry.
- Samples will be transported to the lab for analysis.

Stable Isotope Analysis.

Samples will be sent to the United States to be analyzed for: $\delta^{13}\text{C}$, $\delta^{15}\text{N}$, %N and C:N tissue nutrient concentrations.

Recording Information and Database Format.

The information collected will be entered into an Excel spreadsheet predesigned for the needs of the project. The spreadsheet will be uploaded to the drive storage site for everyone to access. In addition, 2 physical copies will be kept for data security.



Bibliography.

Aronson, R., Bruckner, A., Moore, J., Precht, B., Weil, E., 2008. *Acropora cervicornis*. The IUCN Red List of Threatened Species 2008. IUCN 8235.

Baird, R., Eaton, A.D., Rice, E.W., Bridgewater, L., 2017. *Standard methods: For the examination of water and waste water*, 23rd edit. ed, American Public Health Association. Washington, DC. [https://doi.org/10.1016/0003-2697\(90\)90598-4](https://doi.org/10.1016/0003-2697(90)90598-4)

CCME, 2011. *Protocols manual for water quality sampling in Canada*. Protocols Manual For Water Quality Sampling in Canada.

Cerdeira-Estrada, S., Martínez-Clorio, M.I., Rosique-De La Cruz, L.O., Gonzales-Posada, A.M., Uribe-Martínez, A., Dubois, N., Garza-Pérez, J.R., Álvarez-Filip, L., Cruz-López, M.I., 2018. *Benthic Coverage of the Marine Ecosystems of the Mexican Caribbean: Cabo Catoche- Xcalak 2018* [WWW Document]. *Remote Sens. Ocean. Sea Ice, Coast. Waters, Large Water Reg.* 2011. <https://doi.org/10.1117/12.898652>

Dustan, P. (2021). *Capitalizing on the COVID-19-Pause to Assess the Contribution of Tourism Sewage to Coral Reefs: A Research Proposal to the Waitt Foundation*.

Epa, 2009. Method 1106. 1: Enterococci in Water by Membrane Filtration Using membrane- Enterococcus-Esculin Iron Agar.

Herrera, A., Suárez, P., 2005. Bacterial indicators as tools to measure the environmental quality of coastal water [WWW Document]. *Interciencia*. URL http://ve.scielo.org/scielo.php?script=sci_arttext&pid=S0378-18442005000300011 (accessed 5.25.21).

Maidens, J., Burke, L., 2005. *Belize Coastal Threat Atlas*. World Resour. Inst. 20.

Mumby, P.J., Flower, J., Chollett, I., Box, S.J., Bozec, Y., Fitzsimmons, C., Forster, J., Gill, D., Griffith-Mumby, R., Oxenford, H.A., Peterson, A.M., Stead, S.M., Turner, R. a, Townsley, P., Van Beukering, P.J.H., Booker, F., Brocke, H.J., Cabañillas-Terán, N., Canty, S.W.J., Carricart-Ganivet, J.P., Charlery, J., Dryden, C., Van Duyl, F.C., Enríquez, S., Den Haan, J., Iglesias-Prieto, R., Kennedy, E. V, Mahon, R., Mueller, B., Newman, S.P., Nugues, M.M., Cortés Núñez, J., Nurse, L., Osinga, R., Paris, C.B., Petersen, D., Polunin, N.V.C., Sánchez, C., Schep, S., Stevens, J.R., Vallès, H., Vermeij, M.J.A., Visser, P.M., Whittingham, E., Williams, S.M., 2014. *Reef monitoring for management. Towards Reef Resilience and Sustainable Livelihoods a Handbook for Caribbean Coral Reef Managers* Toward 143–161.

McField, M., Kramer, P., Giró-Petersen, A., Soto, M., Drysdale, I., Craig, N., Rueda-Flores, M., 2020. *Mesoamerican Reef Report*. Heal. Reefs Heal. People Initiat. 36.

O'Dell, J.W., 1993. Method 350.1. Determination of Ammonia, Nitrogen by Semi-automated Colorimetry. Purkis L., 2016. Summary report of satellite mapping of morphological and benthic habitats for the Honduran North Shore. *Smithson. Inst.* 1–6.

Shibata, T., Solo-Gabriele, H.M., Fleming, L.E., Elmir, S., 2004. Monitoring marine recreational water quality using multiple microbial indicators in an urban tropical environment. *NIH Public Access* 23, 1–7. <https://doi.org/10.1016/j.watres.2004.04.044>. Monitoring

Tyberghein, L., Verbruggen, H., Pauly, K., Troupin, C., Mineur, F., Clerck, O. De, 2012. *Bio-ORACLE: a global environmental dataset for marine species* 272–281. <https://doi.org/10.1111/j.1466-8238.2011.00656.x>

Wong, G. T. F., Hou, L. L. T., & Li, K. Y. (2017). Preservation of seawater samples for soluble reactive phosphate, nitrite, and nitrate plus nitrite analyses by the addition of sodium hydroxide. *Limnology and Oceanography: Methods*, 15(3), 320–327. <https://doi.org/10.1002/lom3.10160>

YSI, 2014. *Pro DSS User's Manual*.

Annexes.

ANNEX I. Units for Each Parameter.

| Parameter | Unit of Measurement |
|---------------------------|-----------------------------------------------------------------------------------------------------------|
| Temperature | Sea surface temperature values in ° C |
| pH | Hydrogen potential |
| Total Suspended Solids | Total suspended solid concentration in mg/L |
| Dissolved Oxygen | Dissolved oxygen concentration in mg/L |
| Conductivity (SpCond) | Temperature corrected conductivity in $\mu\text{S} / \text{cm}$ |
| Salinity | Salinity in PSU |
| Turbidity | Turbidity value in FNU |
| Chlorophyll | Chlorophyll in $\mu\text{g/L}$ |
| Enterococcus (average) | Enterococcal bacteria average in MPN / 100mL |
| Total Coliforms NMP/100mL | Total coliforms in MPN / 100mL |
| Nitrate | Nitrates present in the sample in mg/L |
| Nitrite | Nitrites present in the sample in mg/L |
| Ammonia | Original by-product in human wastewater in mg/L |
| Total Phosphorus | Orthophosphate + polyphosphate + organic phosphorus compounds in mg/L |
| N15 | Indicates the proportion of nitrogen in macroalgae derived from human wastewater; measures amount of N15. |

ANNEX II. BICA Field Safety Plan Sheet.

Flotation Plan

Please complete this form before leaving on your boat, leave it with a trusted person who will notify the coast guard and local authorities if you do not return as scheduled, if you are late and it is not an emergency, inform the person with your floating plan to avoid unnecessary search

1. Name of the person presenting this plan: _____
Phone: _____

2. Boat description: Type _____ Registration number: _____ Color: _____
Length: _____ Name: _____

3. Name of person on board: _____ Address: _____
Phone: _____
Phone: _____
Phone: _____
Phone: _____
Phone: _____
Phone: _____
Phone: _____

4. Motor description: Horsepower _____ # de motores _____ Fuel capacity _____

5. Survival equipment on board
 Life jackets Flares Flashlight Signal Mirror Vests
 Anchor Smoke signals Water Food

6. Radio: Type _____ Frequency _____ Call sign _____

7. Travel expectations
 Departing from _____ Destination: _____
 Departing on _____ Date _____ Time _____ am pm
 Date _____ Time _____ am pm

8. Other relevant information: _____

In case of **NOT** returning at the time described in said boat, please call
 Name: _____ Phone number: _____

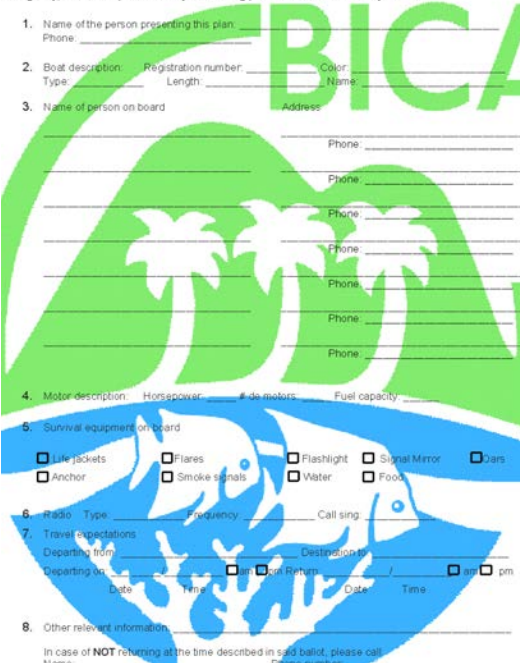

ANNEX III. CZMAI Site Characterization Sheet.



COASTAL ZONE MANAGEMENT AUTHORITY AND INSTITUTE
 Princess Margaret Drive, P.O. Box 1884, Belize City, Belize, Central America
 Tel: 501-223-5739/0719 – Fax: 501-223-5738 – E-mail: coastalplanner@coastalzonebelize.org
 Website: www.coastalzonebelize.org

Appendix 1: Site Characterization Form

Date: _____ Hour: _____ State: _____
 Place: _____ Name of Water Body: _____
 SN: _____

IMPORTANT: Before filling out this form carefully read each of the questions and definitions.

A. BASIC CHARACTERISTICS

1. Mark with an X the type of water body

Sea _____ Lagoon _____ River _____ Stream _____
 Bay _____ Pond _____

2. Specify the coordinates with the precision of tenths of a minute (using GPS procedure)

Latitude: _____ Longitude: _____

3. Briefly indicate the routes of access and if it requires a boat:

4. Indicate the full name of the nearest town. In the event that there is more than one, note those as well:

5. Indicate the means by which you will obtain samples/surveys:

Bridge: _____
 Direct: _____
 Boat: _____

6. Indicate the name(s) of the key person(s) in the area to contact during the calibration of the station. Include address and phone number:



COASTAL ZONE MANAGEMENT AUTHORITY AND INSTITUTE

Princess Margaret Drive, P.O. Box 1884, Belize City, Belize, Central America
 Tel: 501-223-5739/0719 – Fax: 501-223-5738 – E-mail: coastalplanner@coastalzonebelize.org
 Website: www.coastalzonebelize.org

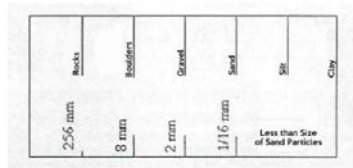

C. CHARACTERISTICS OF WATER BODY

9. At the time of the sampling, point out the conditions of the body of water based on the Beaufort scale, indicate if it was measured or estimated:

0 _____ 1 _____ 2 _____ 3 _____
 4 _____ 5 _____ 6 _____ 7 _____
 8 _____ 9 _____ 10 _____ 11 _____
 12 _____

Beaufort scale is commonly used to characterize conditions in marine water bodies and is based on the speed or force of the wind in such a way that is related with the waves. It comprises 12 values and value mapping is carried out with the altimeter of the speed of the wind with an anemometer and then making knots (1 knot = 1 mph).

Beaufort Scale

| Wind Speed (knots) | Description | |
|--------------------|-------------|-----------------|
| 0 | <1 | Calm |
| 1 | 1-3 | Light Wind |
| 2 | 4-7 | Light Breeze |
| 3 | 8-12 | Gentle Breeze |
| 4 | 13-18 | Moderate Breeze |
| 5 | 19-24 | Cool Breeze |
| 6 | 25-31 | Strong Breeze |
| 7 | 32-38 | Moderate Gale |
| 8 | 39-46 | Fresh Gale |
| 9 | 47-54 | Strong Gale |
| 10 | 55-63 | Whole Gale |
| 11 | 64-75 | Thunderstorm |
| 12 | >75 | Hurricane |

10. Select the options of fauna which are currently present (select those that apply depending on the type of water body):

Fish _____ Aquatic Birds _____ Larva _____
 Insects _____ Other _____



COASTAL ZONE MANAGEMENT AUTHORITY AND INSTITUTE

Princess Margaret Drive, P.O. Box 1884, Belize City, Belize, Central America
 Tel: 501-223-5739/0719 – Fax: 501-223-5738 – E-mail: coastalplanner@coastalzonebelize.org
 Website: www.coastalzonebelize.org

B. HABITAT CHARACTERISTICS

To make the habitat description, it is necessary to delimit/demarcate the area being characterized. This will cover over 100 metres inland from the shore closest to the point of sampling and the subsequent spot will be appointed "area to be characterized". As extensive as possible, there will be a tour of this area to respond to the information that is requested in the form.

7. Indicate the values of environmental variables of the site at the time of sampling.

Ambient temperature (°C) _____ Relative humidity (%) _____

Barometric pressure (mmHG)** _____

Note: Based on these three parameters it is possible to concisely know the environmental conditions.

**The temperature indicates the predominant climate at the time of calibration.*

***The water vapor content in the air is called humidity and relative humidity refers to the highest percentage of humidity possible at a temperature and certain pressure, varying from 100% in fog and 10% in desert conditions.*

****Areas of low pressure are associated with the formation of clouds and rains while high pressures are related to clear skies.*

In the event that you do not have the required measuring equipment, alternatively indicate the qualitative environmental conditions that apply (there can be more than one) at the time of the sampling:

Cold _____ Hot/Warm _____ Sunny _____ Cloudy/Rainy _____ Humid _____ Dry _____

8. Indicate the kind of substrate closest to the station:

Rocks _____ Boulders _____ Gravel _____ Sand _____ Silt _____ Clay _____ Mud _____

Construction: Urban: _____ Industrial: _____

Note: In order to be able to differentiate between rocks, sand and fine sediments such as silt or clay an annex table will be used which indicates the size of the sediment, these sizes can be compared through the use of a ruler about 30 cm long that has the millimeters and the centimeters marked. It is difficult to make the measurement with the finer sediments a practical way to differentiate them is by their texture: the sand has a grainy and the silt and clays have a smooth and fine texture.



COASTAL ZONE MANAGEMENT AUTHORITY AND INSTITUTE

Princess Margaret Drive, P.O. Box 1884, Belize City, Belize, Central America
 Tel: 501-223-5739/0719 – Fax: 501-223-5738 – E-mail: coastalplanner@coastalzonebelize.org
 Website: www.coastalzonebelize.org

11. Indicate

the type of
 vegetation of the body of water in the vicinity of the site.

Keip (*Macrocystis* sp), up to 30m _____

Sea Lettuce, (*Ulva* sp), up to 20m _____

Sea Grass, (*Enteromorpha* sp), up to 40cm _____

Sea Weed, (*Sargassum* sp), 20-100cm _____

12. Extra comments. This space is to make any annotation with respect to very particular aspects of the body of water that have not been considered in the previous questions.

D. ALTERATIONS OF THE BODY OF WATER (SIGNS OF CONTAMINATION)

13. Select all signs of water pollution that apply:

Foam _____
 Sewage _____
 Oils and Combustible fuels _____
 Solid Waste _____
 No Contaminants _____

14. Do you smell a bad odour?



COASTAL ZONE MANAGEMENT AUTHORITY AND INSTITUTE

Princess Margaret Drive, P.O. Box 1884, Belize City, Belize, Central America
Tel: 501-223-5739/0719 – Fax: 501-223-5738 – E-mail: coastalplanner@coastalzonebelize.org
Website: www.coastalzonebelize.org

Yes _____ Describe the smell (hydrogen sulphide, sewage, etc.)

15. Colour: Select all the signs of contamination (select those that apply depending on the type of water body)

Black _____ Dark Green _____ Grey _____ Brown _____

Other (Specify what it is) _____ No Color _____

16. Formation of bubbles near the sediment of the water body (If applicable).

Yes _____

No _____

17. Extra comments. This space is to make any annotation with respect to very specific aspects of the alterations of the body of water that has not been considered in the previous questions.-

E. HUMAN ACTIVITIES RELATED TO THE BODY OF WATER

18. Briefly discuss and describe the activities related to the body of water in the vicinity of the site monitoring.

F. LANDSCAPE SKETCH

Hand sketch a map of the monitoring site, taking into account that the sampling site should be the main focus of the area represented in the drawing. Indicate references to help you easily locate site, toggle points of the compass, indicate the road access to the site or indicate the distance to the embarkation site. no measures will be allocated specific for the realization of the drawing, because the morphology and dimensions of the lagoons and bays change along the coastline, the dimensions will be given in accordance with the shape of the lagoon/Bay and the visual scope of the observer.



COASTAL ZONE MANAGEMENT AUTHORITY AND INSTITUTE

Princess Margaret Drive, P.O. Box 1884, Belize City, Belize, Central America
Tel: 501-223-5739/0719 – Fax: 501-223-5738 – E-mail: coastalplanner@coastalzonebelize.org
Website: www.coastalzonebelize.org

G. TAKING PHOTOS

- Take at least four photographs which detail the sampling site as well and its surroundings including points of reference (lamp posts, significant trees).
- If a nearby bridge exists, check the possibility of taking some pictures from the bridge to get a panoramic view of the site, an example would be a bridge over a pond outlet.
- It is recommended that you take pictures from the boat and toward points of reference on the nearest shore. (where applicable)
- It is recommended that the photographer is placed in a safe place (away from the Bank of the stream, not to step on loose stones or sludge) to avoid any mishaps.
- The photos must be taken in good lighting while not facing the sun.



CORAL
REEF ALLIANCE

coral.org | 1.888.CORAL.REEF | info@coral.org